



GMX-2500 setup and operation

When opening the box, you should find:

- The mixer GMX-2500
- The 19" rack mount brackets (pre-installed)
- Equalizer protective cover plate (pre-installed)
- Two adapters: phone/RCA for the front line inputs
- Powercord

Unit dimensions:

435 mm x 280 mm x 88 mm (without rack mount brackets)

Weight:

4.4 kg net, 5.9 kg shipping

After unpacking the mixer please plug in the delivered power cord into the power input jack of the unit. Before connecting the mixer to the wall outlet, make sure that the "POWER" switch on the right of the front side is in "OFF" position. Also the main volume control (MASTER) should be set fully counterclockwise ("0" position).

Attention: Due to safety reasons the case never should be opened by the user. Beside, this also may void any warranty claims!

Now you may connect the mixer to a wall mains outlet. Please make sure you first switch on the GMX-2500 and then the power amplifier. This way you avoid annoying audible transient noise.

controls on the front side



On the left hand side you will find the 3 pin XLR female connectors (1), the microphone inputs for connecting balanced microphones. Close by on the right is a recessed push button (2) for activation of phantom power when using condenser microphones. When dynamic microphones are hooked up, the switch remains in the "OFF" position. Please note, that the microphone inputs on the front and on the rear side are used in parallel. This means that you may *either* use the front- or the rear inputs, not both of the XLR input pairs *simultaneously*.

Beneath the XLR inputs you will find two 1/4" phone jack inputs (3). These are line level inputs, for example to connect a stereo keyboard or a device for playback music. The left phone jack is a stereo type (TRS) e.g. tip = left channel, ring = right channel input. When using mono phone plugs connect left and right plugs as printed on the housing. In case you want to use a cable with RCA connectors, we have enclosed two suitable adapters in the packaging for your convenience.



Bedienelemente Frontseite (Forts.)

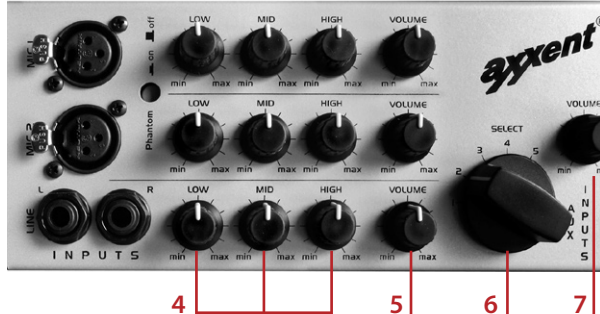

Each of the three front inputs provides a 3 band equalizer (4), "LOW, MID and HIGH" and a volume level control (5).

Located right from the volume controls is the 5-position source select switch (6) (SELECT). With this rotary knob you easily can select any of the 5 RCA stereo inputs on the rear side of the mixer, labelled AUX1 to AUX5. Typically these inputs are used to connect CD/MP3 player, cassette player, tuner or similar devices. Right of the source selector knob you will find the volume control (7) for the selected source.

In the middle of the front panel you surely will see the protection plate, covering the 7 band equalizer. Reason for this cover plate is to protect the equalizer settings made by an acoustic engineer after calibrating the complete system. If you may want to make your own sound adjustments, and no calibration settings by an acoustical expert must be protected against unwanted changes, feel free to remove this metal cover plate. The gain range of the equalizer is limited to ± 6 dB by intention in order to avoid extreme setting which may result in an unwanted "twisted" frequency response and also may cause damage to the system or components.



On the right hand side of the GMX-2500 you will see the output volume controls, one for the "MASTER" (9), the main stereo output, and two smaller control knobs (8) for adjusting the level of the two mono zones. For example the stereo main output may be used in a pub or bistro to drive the main loudspeakers, a zone output for the washrooms/hallways and another one for separate smaller room. The balanced XLR output jacks for the mentioned different PA areas are located on the rear side. Above the "MASTER" volume control you see a row of three LED indicators (10) for *power on*, *signal presence* and for the *limiter activity*.

Limiter: Located on the right bottom side of the front panel you see two recessed controls for the limiter, one is the on/off switch and the upper is the screwdriver adjustable setting for the limiter attenuation level.

The limiter is an important tool to keep the sound pressure level (SPL) within a prefixed maximum, for example if government rules do not allow SPLs above a certain maximum level. With this limiter you can rest assured that this maximum level is not exceeded—and you even can have this maximum level measured and calibrated by an acoustic engineer and have it officially sealed. The output level of the GMX-2500 may be attenuated up to 30 dB. Last not least above the limiter section you may have already noticed the "POWER" switch. No further explanation necessary here...





Connections on the rear panel

Left hand side on the bottom is the mains fuse holder (2) and the fuse switch (1). Should the fuse really gets blown, please replace it with a fuse of the same type (63 mA, slow blow). Should this happen again do not use another "stronger" type of fuse or unscrew and open the unit. In this case please call your dealer or installer for repair.

We already mentioned the five RCA stereo aux inputs (4) on the rear panel. Left from these you will notice RCA jacks labelled "REC" (3). These are, we think you guessed it, intended for recording purposes (tape-/cassette recorder etc.).

Above these RCA jacks are the XLR outputs. "RIGHT" and "LEFT" (5) are the stereo main outputs, the other two the mono outputs for ZONE 1 and ZONE 2. Right hand on the bottom are the XLR microphone inputs (6), connected in parallel wit the corresponding inputs on the front side (*only use either one!*)

The GMX-2500 is delivered from factory with ready installed rack mounts ("ears") for mounting in a standard 19" rack. These rack mounting brackets are easily detachable for setting up the mixer on a table or any other surface.

Now there is nothing left but wishing you trouble free operation of the GMX-2500. Enjoy the excellent sound it delivers.



DECLARATION OF CONFORMITY

We declare as our sole responsibility that this product is in compliance with the EMC Directive 89/336/EEC and conforms to the requirements of the Harmonized Product Standards EN 55013 (Product Emissions), and EN 55020 (Product Immunity).



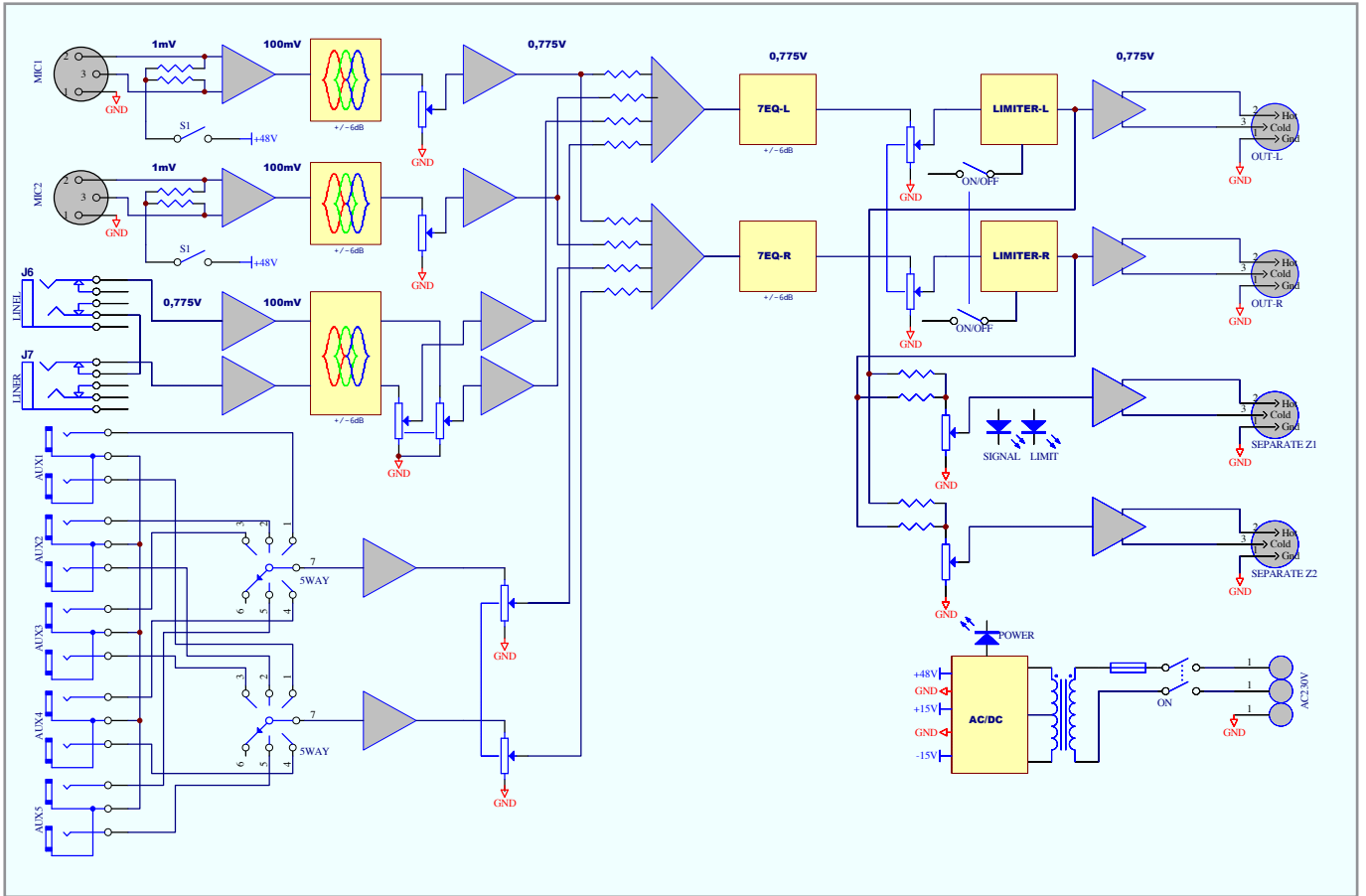

Blockdiagram of the Gastro-Mixer GMX-2500